

TRU-BOLT® Classic

Digital Lever with Keypad

ENGLISH

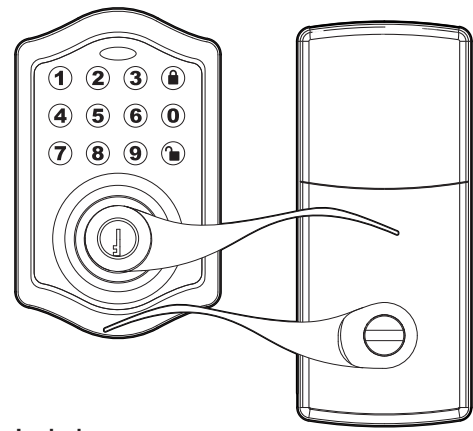

Package Includes:

- 1 - Exterior Faceplate
- 1 - Interior Faceplate
- 1 - User Guide
- 2 - Keys
- 1 - Strike Plate
- 1 - Mounting Plate
- 1 - Latch
- 1 - 3/8" Screws
- 2 - 5/16" Screws
- 2 - 1" Screws
- 4 - 3/4" Screws
- 1 - Optional Set Screw

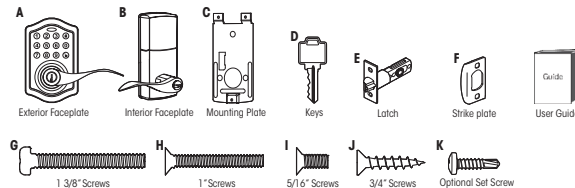

Please carefully check the above list to confirm all items have been received. If any items are missing, please contact Consumer Assistance (See page for contact information).

Read this manual carefully before installing and operating!

Model 1740024, 1740026, 1740028, 1740030

1 Installation Overview

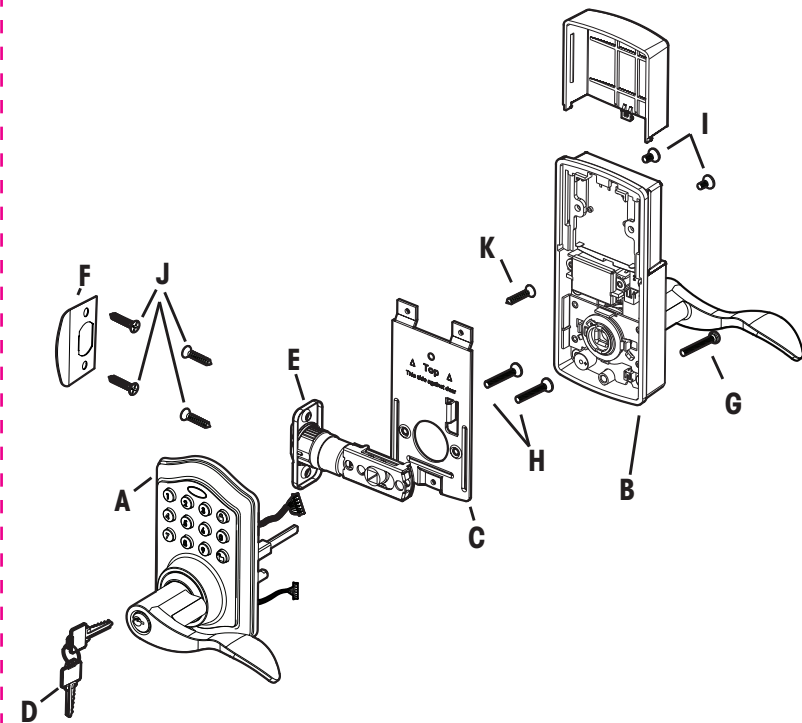

Lever Assembly

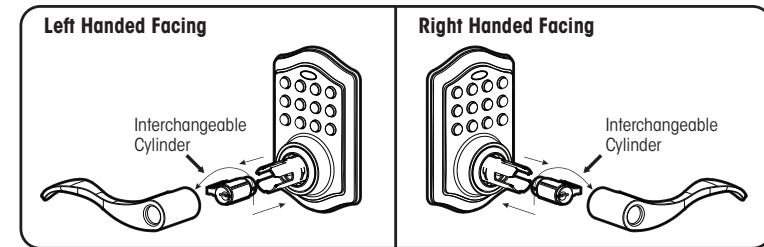

2 Preparing Door

Refer to Template for Door Prep Instructions Included in packaging.

NOTE: Skip this step if your door comes with pre-drilled holes.

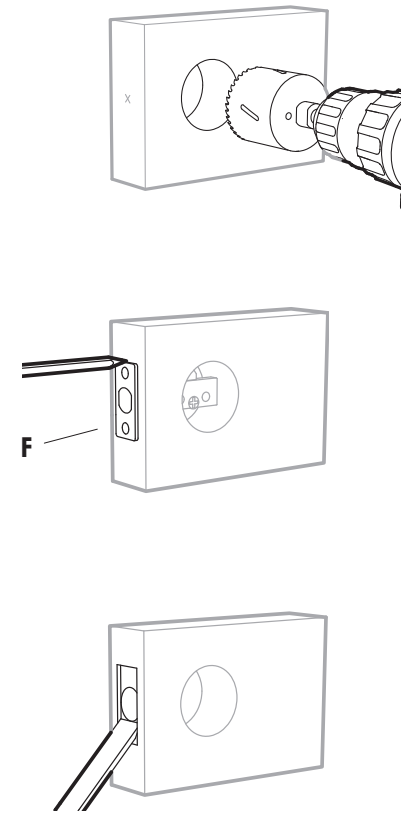

3 Install Enclosed Latch and Strike Plate

NOTE: Do not extend Cylindrical Cover past 2-3/4" (70mm).

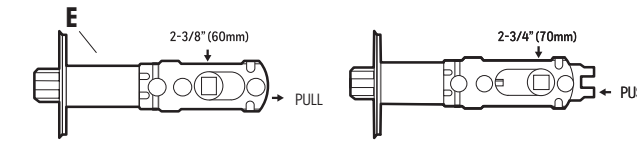

TO CONVERT FROM 2-3/8" (60mm) BACKSET TO 2-3/4" (70mm) BACKSET
1. Hold latch with numbers facing forward and thumb pressing on the latch.
2. Pull or Push the extension plate to the required size.

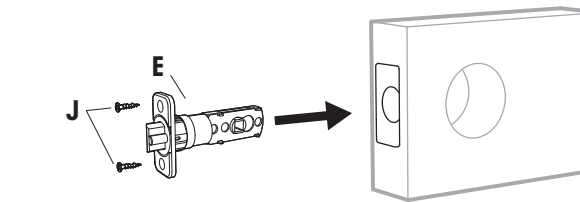

Strike Plate

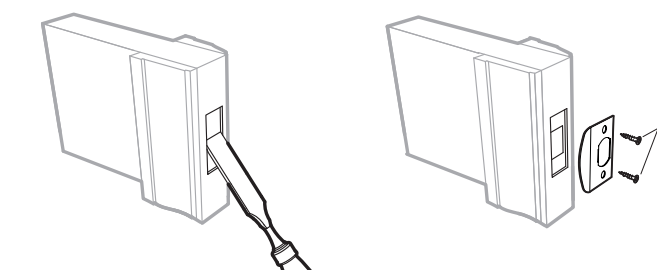

4 Install Exterior Assembly

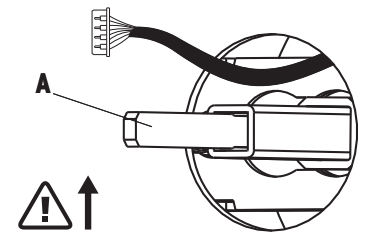
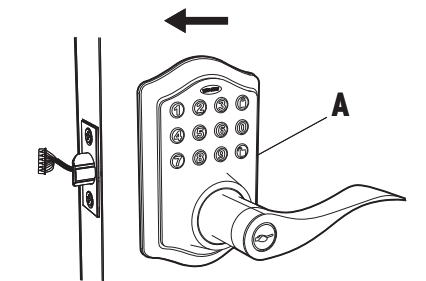

Check that the Rubber Gasket is secured on the Exterior Assembly. Insert the Exterior Assembly onto the door with the tailpiece going through the Latch Set in the VERTICAL POSITION. Route the Control Wire through the door above the Latch Set.

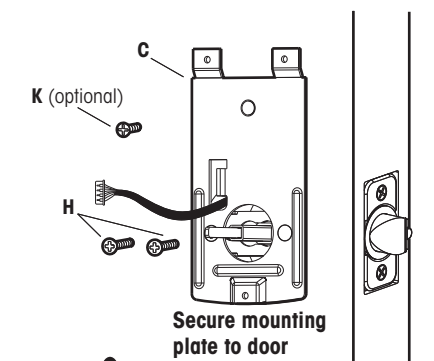

Do Not Over Tighten

5 Install Interior Assembly

Work with the door open.

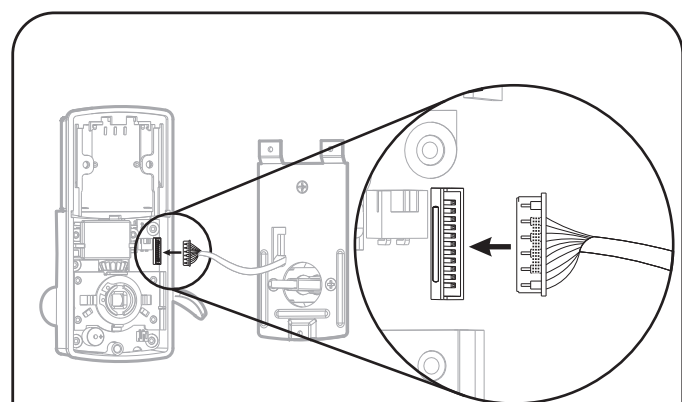
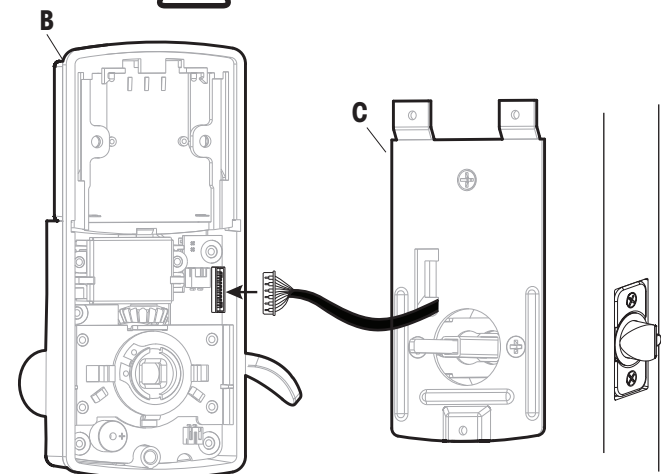

IMPORTANT: Make sure the connector dots line up with the dots on the wire.

6 Install Interior Assembly

NOTE: Make sure the knob is in the vertical position. Be careful not to pinch the control wire when assembling.

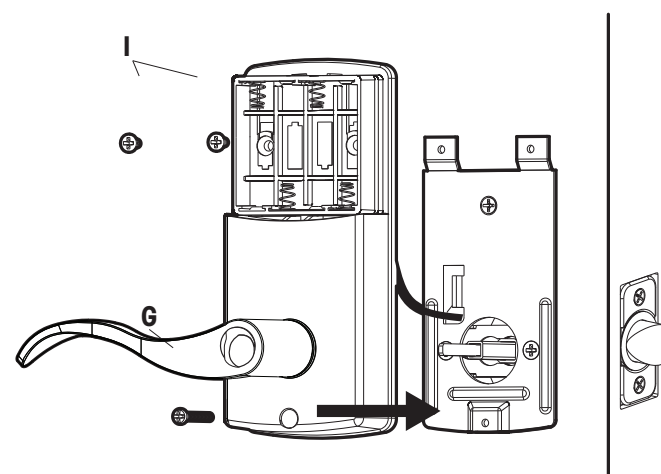

Test the lock

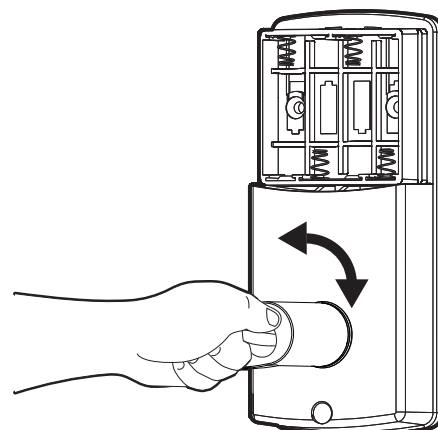

Lock and unlock using the knob make sure the latch is opening and closing easily. If not, go back to step 2 and ensure you followed the steps.

7 Install Batteries and Cover

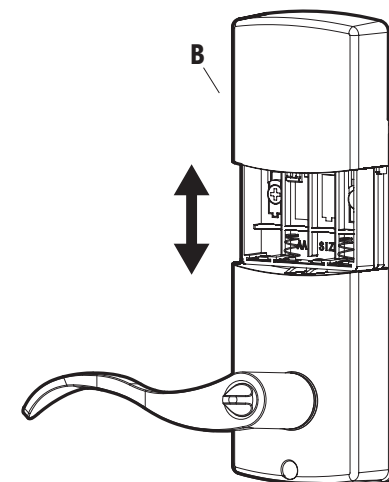

This Electronic lock requires (4) High Quality AA Alkaline batteries. When all 4 batteries are installed in the correct position, you should hear 2 beeps and the keypad will illuminate.

NOTE: Do not touch the Keypad until the light turns off. Do not use rechargeable batteries or non-alkaline batteries.

8 Testing Operation

Test the lock button with door open



Test unlocking
Press 1-2-3-4

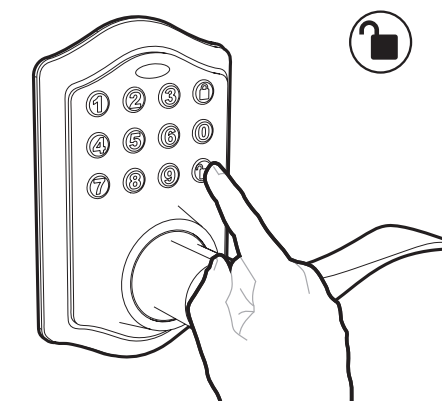

Before Opening Door Let Motor Complete Cycle.

9 Reversing Lock Handing

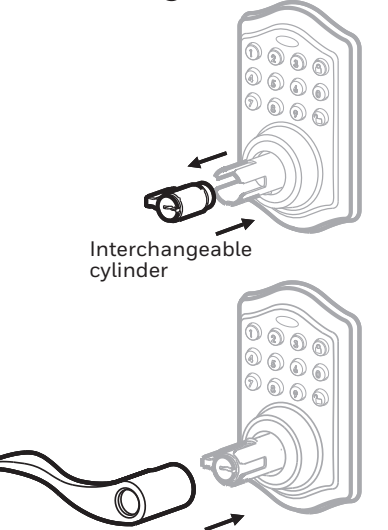
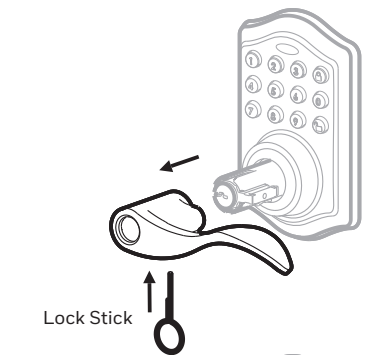

Congratulations, You have Installed the TruBolt Classic Electronic Lever (1740024 1740026 1740028 1740030) Turn Sheet over for Programming Instructions.

M1740024 1740026 1740028 1740030 V3 E

Programming Instructions

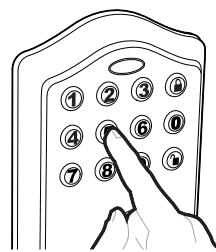
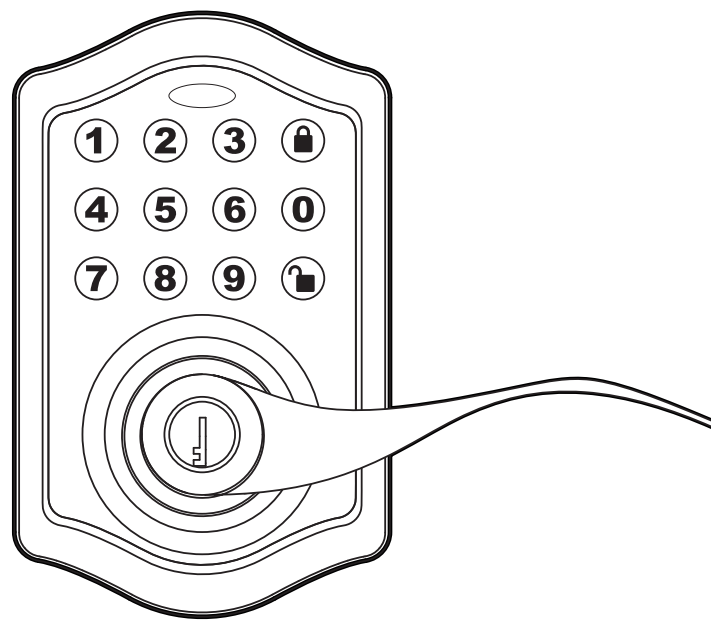

! Complete all the programming steps in the programming mode within 5 seconds. Do not press keypad until keypad stops illuminating.

1 Creating Administrator Code

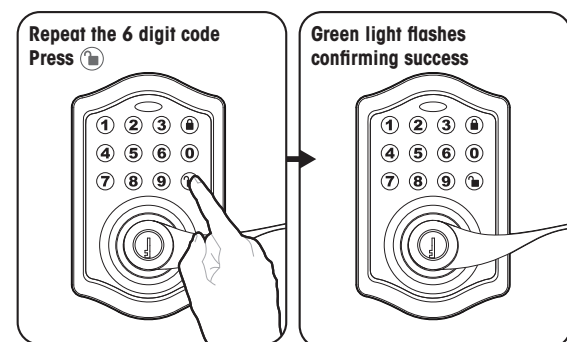
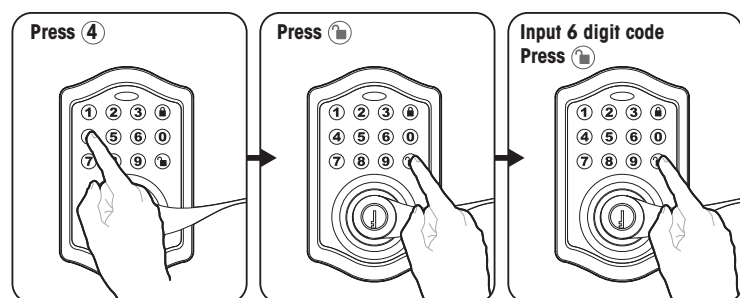
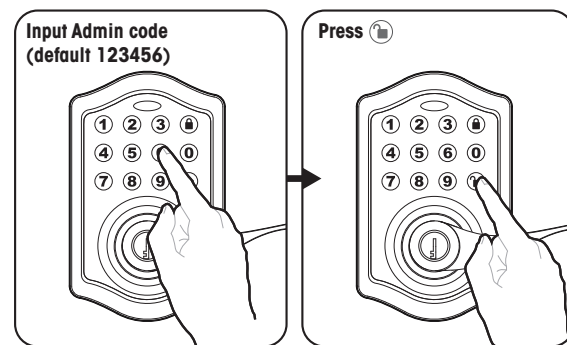

2 Adding a User Code

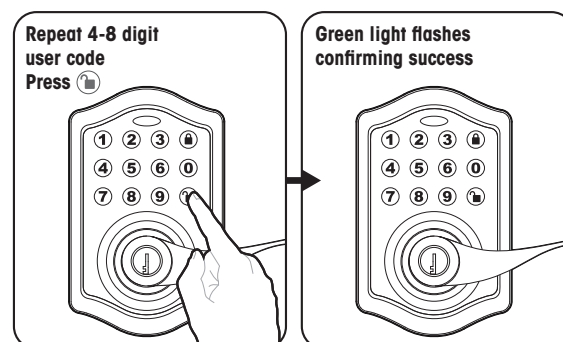
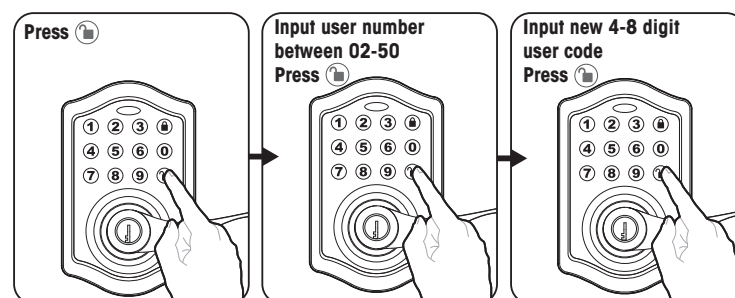
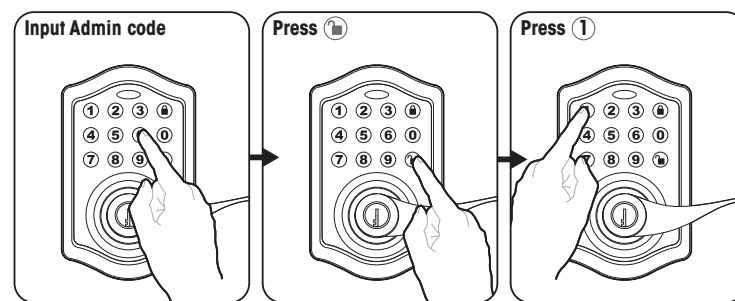

3 Unlocking Door with User Code

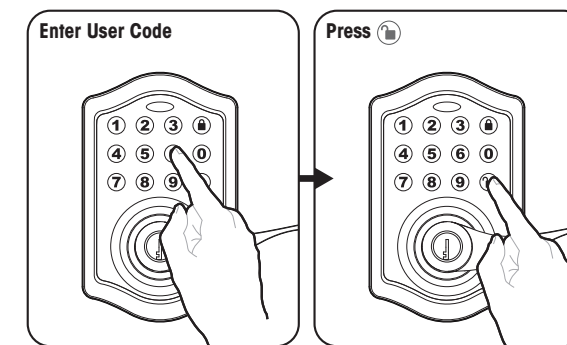

PROGRAMMING RECORD

My Codes:	Date Created
Programming Code _____ (6 digits) / /	
User Code 02 _____ (4-8 digits) / /	
User Code 03 _____ (4-8 digits) / /	
User Code 04 _____ (4-8 digits) / /	
User Code 05 _____ (4-8 digits) / /	
User Code 06 _____ (4-8 digits) / /	
User Code 07 _____ (4-8 digits) / /	
User Code 09 _____ (4-8 digits) / /	
User Code 10 _____ (4-8 digits) / /	
User Code 11 _____ (4-8 digits) / /	
User Code 12 _____ (4-8 digits) / /	
User Code 13 _____ (4-8 digits) / /	
User Code 14 _____ (4-8 digits) / /	
User Code 15 _____ (4-8 digits) / /	
User Code 16 _____ (4-8 digits) / /	
User Code 17 _____ (4-8 digits) / /	
User Code 18 _____ (4-8 digits) / /	

4 Deleting a User Code

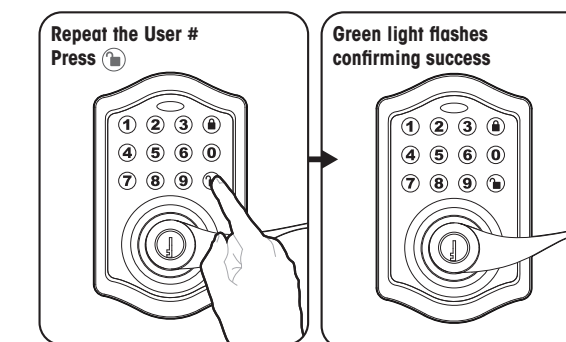
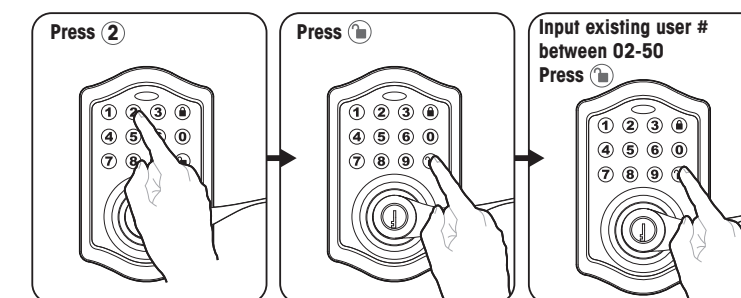
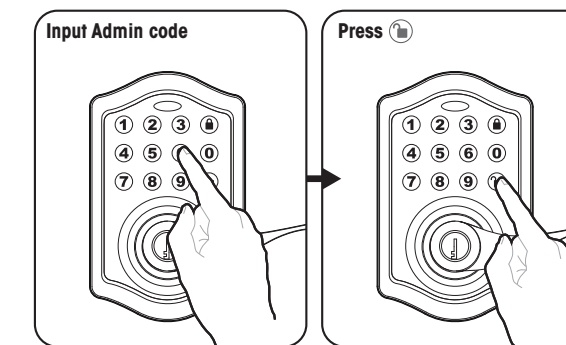

5 Deleting All User Codes

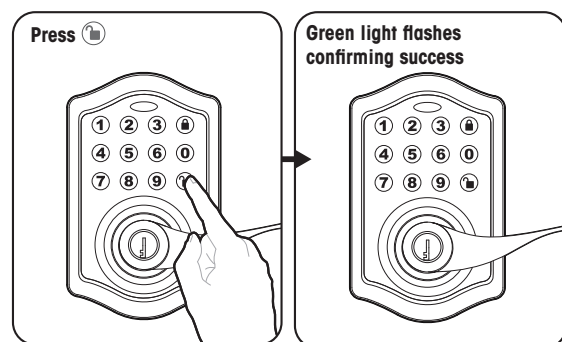
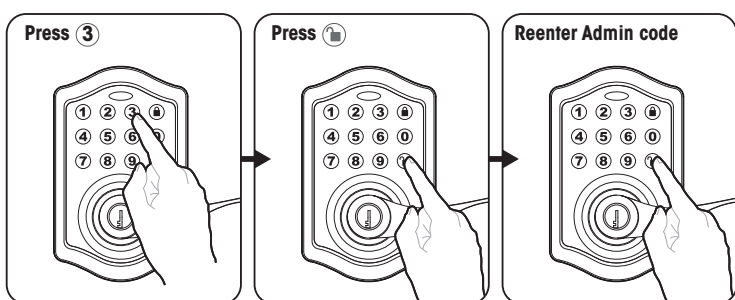
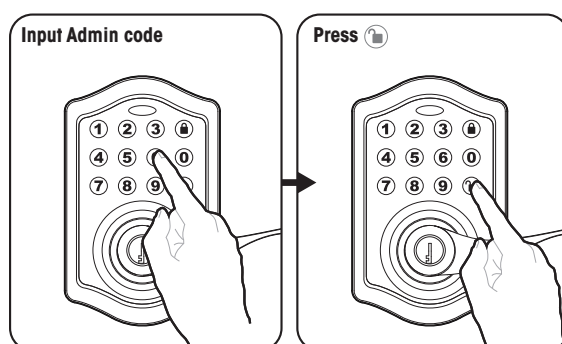

6 Additional Programming Functions

Programming Symbols

- Lock / Clear
- Unlock / Programming
- Administrator Code

Automatic Lock Function

SET OR CANCEL AUTO LOCK

You can set the lock to automatically close after each time the lock is opened. Time value range = 20 - 900 seconds, enter the following:

Set Auto Lock: → → 5 → → Time Value →

Hear 1 beep and Light Indicator illuminates green.

To cancel Auto Lock set the time to 00, enter the following:

Cancel Time Value Auto Lock: → → 5 → → 00 →

Hear 1 beep and Light Indicator illuminates green.

TEMPORARILY DISABLE:

While in Auto-Lock mode, unlock door using , within 10 seconds you must turn the locking knob by hand to the locked position, wait more than 2 seconds then turn the locking knob back to the unlock position. The Auto-Lock mode is now disabled.

RESTORE:

To restore the Auto-Lock function, turn the locking knob by hand to the locked position, wait more than 2 seconds or press the Lock button on the keypad.

Vacation Mode

With Vacation Mode enabled, the system enters into low-power consumption mode. During this mode, all buttons and functions will be disabled until they are re-enabled.

ENABLE:

→ → 10 → → 1 →

Once the door is locked then vacation mode will be engaged and all buttons and functions will be disabled

DISABLE:

To disable the Vacation Mode, you must press and hold for more than 3 seconds, then input followed by to unlock the door. Vacation Mode is now disabled.

! NOTE: If you only press the for more than 3 seconds but do not input , the system will remain in Vacation Mode.

Secure Lock-out period

Warning sounds and LED flashes red after 4 incorrect code attempts: Keypad shuts down for 60 seconds.

7 Additional Programming Functions

SOUND ON AND OFF

You can "mute" or turn the "sound on" on your lock by entering the following. (Factory setting is sound on).

→ → 6 → → 1 or 2 →

1 = Sound Off

2 = Sound On

Sound Off (1) - Light Indicator illuminates green.

Sound On (2) - Hear 1 beep and Light Indicator illuminates green.

Restore Factory Settings

To reset the lock to the original factory settings including the Programming Code and all User Codes follow these steps:

1. Remove one battery for 10 seconds.
2. Reinsert the battery and wait for a long and short beep
3. Press 3 times within 3 seconds.
4. The lock will beep and the light indicator will turn green.

Low Battery Warning

Beeps and LED flashes red 7 times. Replace with good quality alkaline batteries.

Note: Removing batteries does not erase active Administrator or User Codes.

Consumer Friendly Message Guide

Unlock / Valid programming:	1 long beep and LED illuminates green
Lock:	2 short beeps and LED illuminates red
Invalid Programming:	2 short beeps and LED flashes red twice
Low Voltage:	Short beeps and LED flashes red seven times
Super Low Voltage:	4 short beeps and LED flashes red four times
4 Incorrect code entry attempts:	2 short beeps and LED illuminates red each attempt
Power on:	1 long beep and 1 short beep and LED illuminates green
Chip Reset:	1 long beep and 1 short beep and LED illuminates green (may occur several times or once in a while)
Lock Error:	3 long beeps LED flashes red three times
Repeat operation after Lock Error:	2 short beeps three times LED flashes red six times

Troubleshooting

Issue	Solution
Interior Knob will not turn	<ul style="list-style-type: none"> Knob or vertical tailpiece is installed in incorrect position. Remove Interior Assembly and reposition the Interior Knob. With the Deadbolt Latch retracted verify that the tailpiece is vertical.
Lock will not function electronically	<ul style="list-style-type: none"> Check that all batteries are high quality Alkaline Batteries. Check for proper polarity (+ -) of all batteries. Check that the Control Wire is attached to the Interior Assembly and not damaged. Check each wire for loose or disconnected wires. Disconnect the wiring harness and reconnect the wiring harness.
Lock gives error signal when opening or locking and Deadbolt Latch will not extend or retract completely when door is closed	<ul style="list-style-type: none"> Unlock door using Key or Interior Knob. While door is open, check that the Deadbolt Latch operates smoothly. Check for proper alignment of the strike plate, adjust as needed to assure there is no binding against the Deadbolt Latch. Make sure tail piece is in the vertical position and straight up and down.
Deadbolt Latch is sticking	<ul style="list-style-type: none"> Installation screws of the lock may be too tight and have to be loosened. Remove Interior Assembly. Slightly loosen the Mounting Plate screws. Lock and unlock using the Key. Reattach Control Wire and Interior Assembly.
Keypad not working	<ul style="list-style-type: none"> Wait 60 seconds, keypad may be locked out due to incorrect code. Replace with 4 high quality alkaline batteries.
Keypad beeps and LED flashes	<ul style="list-style-type: none"> Replace with 4 high quality alkaline batteries.

Limited 1-Year Electronic Warranty

Limited Lifetime Mechanical and Finish Warranty

This Tru-Bolt® product comes with a 1-Year Limited Warranty on Electronic Parts and a Limited Lifetime Mechanical and Finish Warranty against defects in materials and workmanship under normal use to the original residential user. Proof of purchase and ownership is required for the warranty to be in effect. This warranty is non-transferable and applies to the original purchaser only, as long as the original purchaser occupies the residential premises upon which the product(s) was originally installed. This warranty DOES NOT COVER removal and reinstallation of product(s), scratches, abrasions, deterioration due to the use of paints, solvents or other chemicals, abuse, misuse, or product(s) used in commercial applications, does not cover any losses, injuries to persons/property or costs, and shipping and freight expenses required to return product(s). In no event shall Tru-Bolt® be liable for any special, incidental or consequential damages. If this product(s) is considered a consumer product, please be advised that some local and state laws do not allow limitations on incidental or consequential damages or how long an implied warranty lasts, so that the above limitations may not fully apply. Refer to your local laws for your specific rights under this warranty. If there are any problems please call our customer service with any questions or concerns.

DO NOT RETURN TO STORE!

If any parts are missing or damaged, please call Customer Service Toll free at 1-800-860-1677 (Toll Free, M-F 7am – 5pm PST).

Online installation videos can be viewed at TruBoltLocks.info.

Contact Us First! Do Not Return to Store

EMAIL: locks@lewishymaninc.com
 WEBSITE: www.truboltlocks.info
 ADDRESS: Consumer Assistance Dept.
 Lewis Hyman, Inc.
 860 East Sandhill Avenue
 Carson, CA 90746 USA
 TELEPHONE: US/Canada 800-860-1677 Ext. 1801 (Toll Free)