

TRU-BOLT®
Classic
Electronic Knob with Keypad

ENGLISH

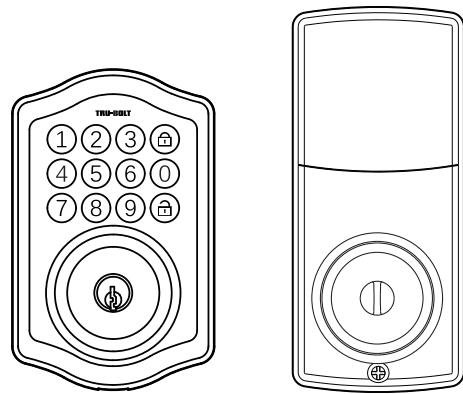

Read this manual carefully before installing and operating!

Important
Use the QR code below for the most up to date instructions:



Tools Needed for Lock Installation:

- Phillips Screwdriver



1 Installation Overview

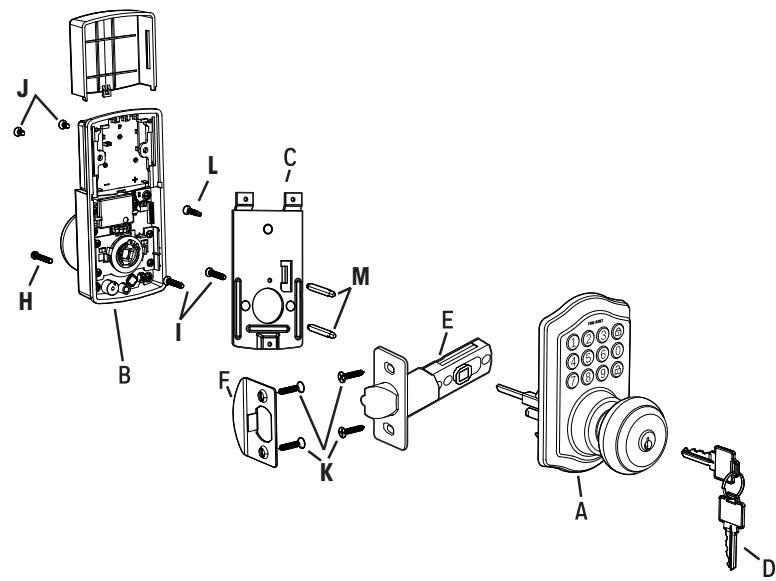

Package Includes:

- | | | |
|------------------------|--------------------|------------------------|
| 1 - Exterior Faceplate | 1 - Strike Plate | 2 - 5/16" Screws |
| 1 - Interior Faceplate | 1 - Mounting Plate | 2 - 1" Screws |
| 1 - User Guide | 1 - Latch | 4 - 3/4" Screws |
| 2 - Keys | 1 - 1 3/8" Screws | 2 - Mounting Post |
| | | 1 - Optional Set Screw |

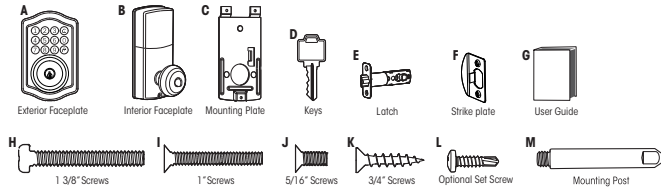

Please carefully check the above list to confirm all items have been received. If any items are missing, please contact Consumer Assistance. (See back for contact information)

Read this manual carefully before installing and operating!

2 Install Enclosed Latch and Strike Plate

Do not over-tighten latch screws.

NOTE: Do not extend Cylindrical Cover past 2-3/4" (70mm).

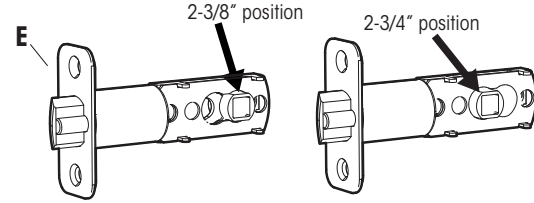

- TO CONVERT FROM 2-3/8" (60mm) BACKSET TO 2-3/4" (70mm) BACKSET:
1. Hold latch with numbers facing forward and thumb pressing on the bolt.
 2. Rotate the cylinder cover clockwise.
 3. Pull and twist the extension plate all the way out.
 4. Rotate the cylinder counter clockwise so that the marking aligns with the 2-3/4" position indicator.

The latch plate on the door needs to be straight and not protruding from door. Make adjustment before installing or this will cause problems with bolt fitting into latch hole.

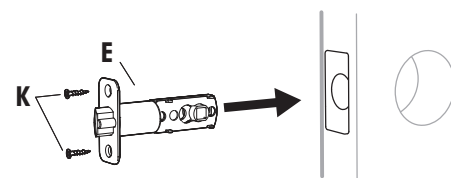

Preparation for Interior Assembly.

Remove (J) Screw from inside the battery compartment within the (B) Housing to release the Mounting Plate (C).

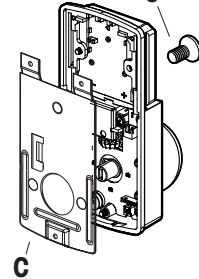

Screw Mounting Post (M) into holes on Mounting Plate (C).

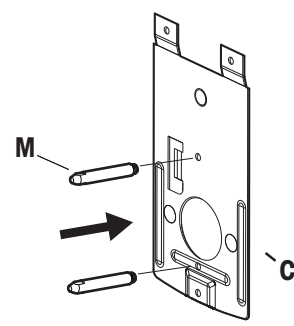

3 Install Exterior Assembly

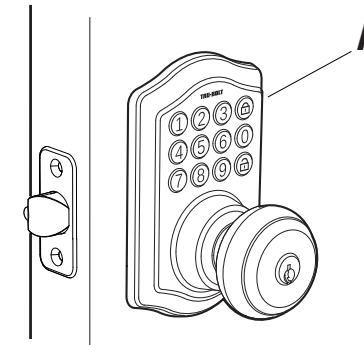

Check that the Rubber Gasket is secured on the Exterior Assembly. Insert the Exterior Assembly onto the door with the tailpiece going through the door with the tailpiece going through the Latch Set in the VERTICAL POSITION.

Route the Control Wire through the door ABOVE the Latch Set. **Make sure the door is shut, lock and unlock using the key, ensure that the latch is operating smoothly and is aligned properly without scraping the strike plate.** If not, go back to step 2 and ensure you followed the steps.

VERTICAL POSITION

Work with the door open

(L) screw goes into the door to prevent the lock from shifting and is optional.

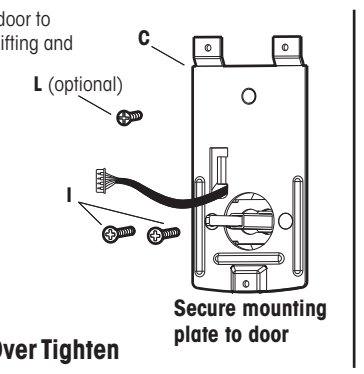

Do Not Over Tighten

4 Install Interior Assembly

Carefully insert control wire into the wire connector

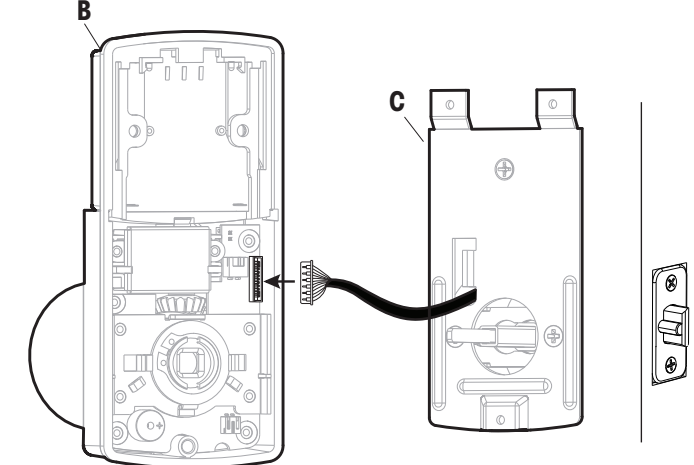

Work with the door open

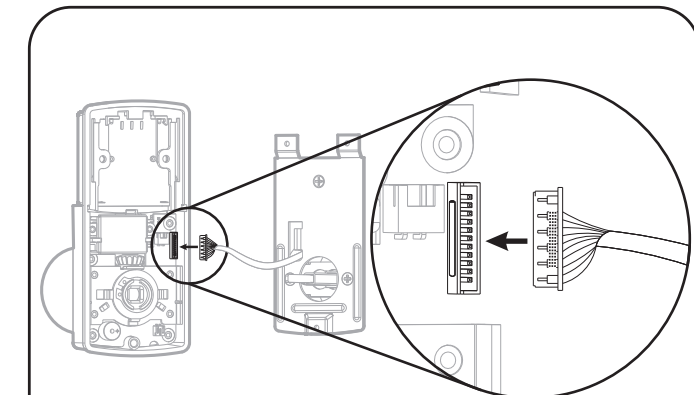

NOTE: Make sure the connector dots line up with the dots on the control wire

5 Install Interior Assembly

NOTE: Make sure the Turn Knob is in the correct position. Be careful not to pinch the control wire when assembling.

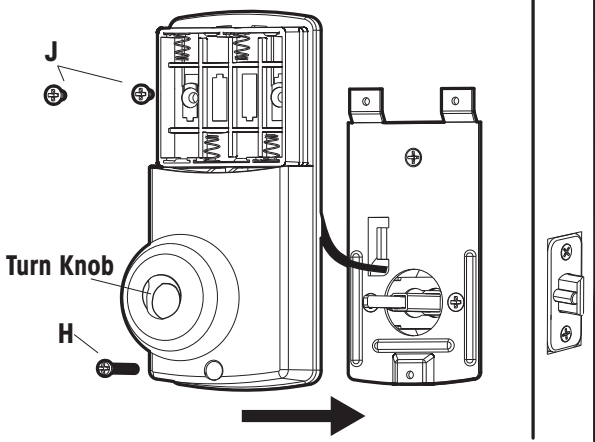

Test the lock

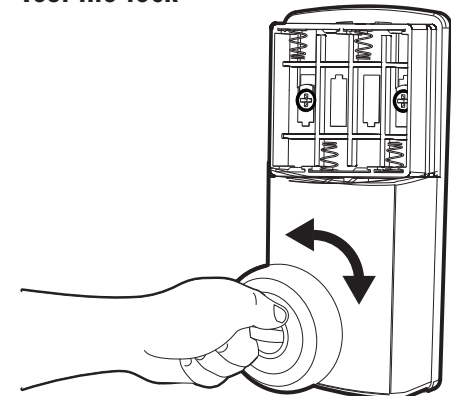

Lock and unlock using the turn knob make, sure the latch is opening and closing easily. If not, go back to step 2 and ensure you followed the steps.

6 Install Batteries and Cover

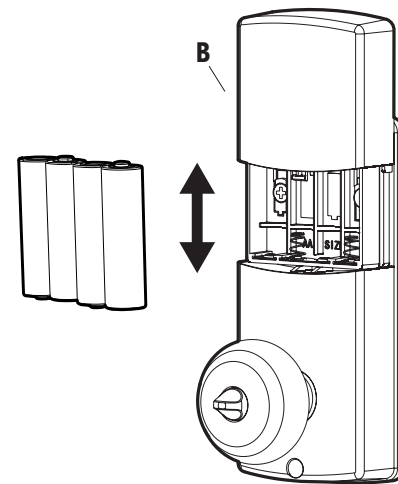

This Electronic lock requires (4) High Quality AA Alkaline batteries. When all 4 batteries are installed in the correct position, you should hear 2 beeps and the keypad will illuminate.

NOTE: Do not touch the Keypad until the light turns off. Do not use rechargeable batteries or non-alkaline batteries.

Before Opening Door Let Motor Complete Cycle

7 Testing Operation

Test the lock button with door open

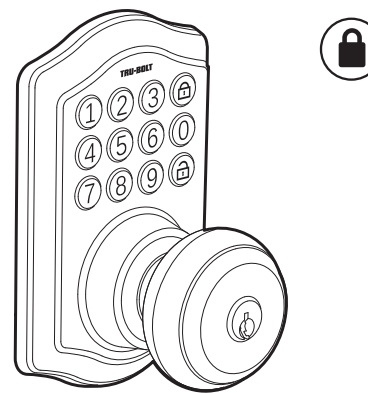

Test unlocking Press 1-2-3-4



Preparing Door

Tools Needed for Door Preparation (if there is no knob hole):

- Drill
- 2 1/8" Hole Saw
- 1" Hole Saw
- 3/4" Chisel

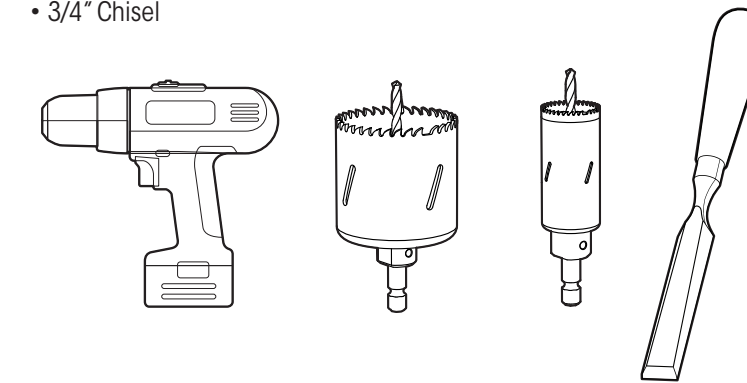

NOTE: Skip this step if your door comes with pre-drilled holes.

Refer to Template included for Door Prep Instructions

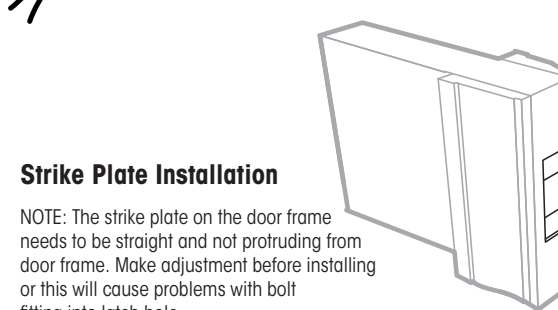
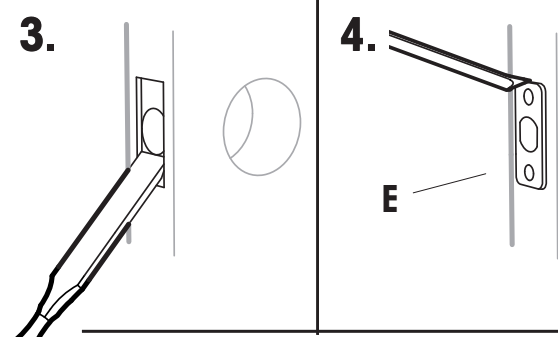
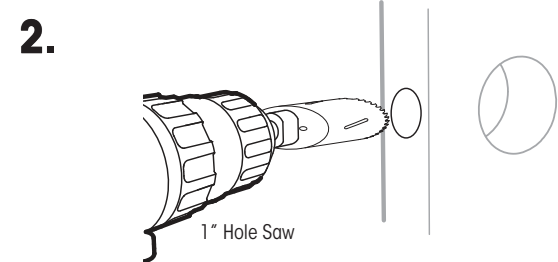
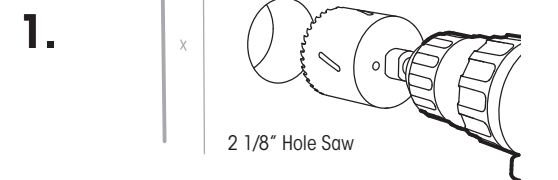
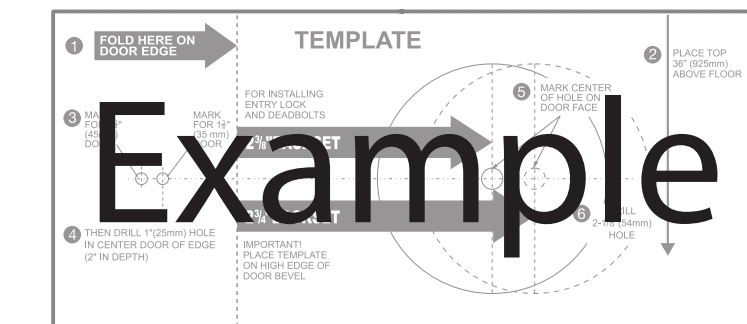

Strike Plate Installation

NOTE: The strike plate on the door frame needs to be straight and not protruding from door frame. Make adjustment before installing or this will cause problems with bolt fitting into latch hole.

Programming Instructions

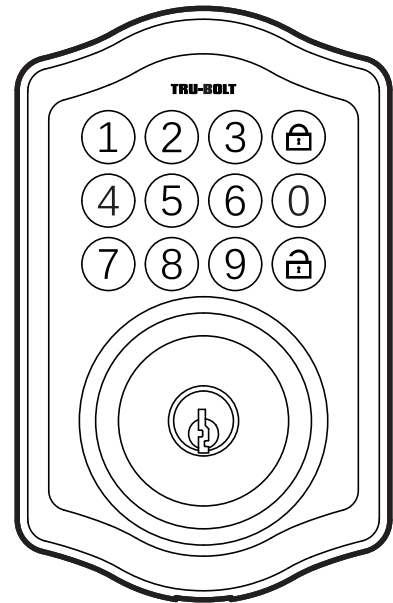

Read this manual carefully before Programming and operating!



Complete all the programming steps in the programming mode within 5 seconds
Do not press keypad until keypad stops illuminating

1 Creating Administrator Code

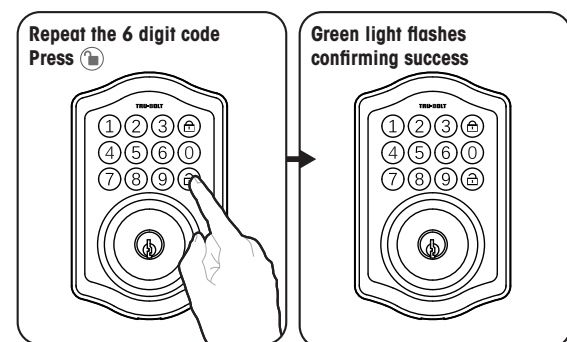
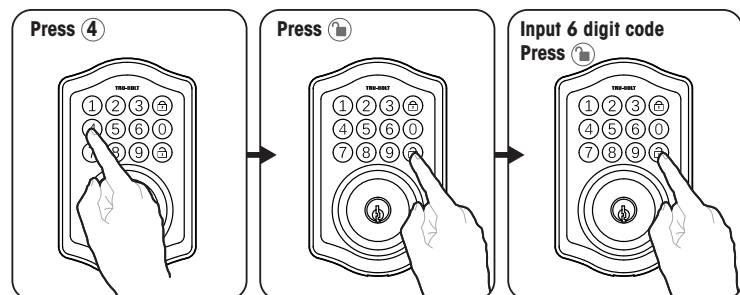
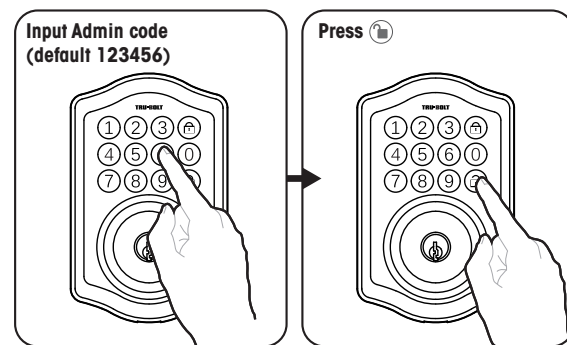

6 Digit Admin Code _____

2 Adding a User Code

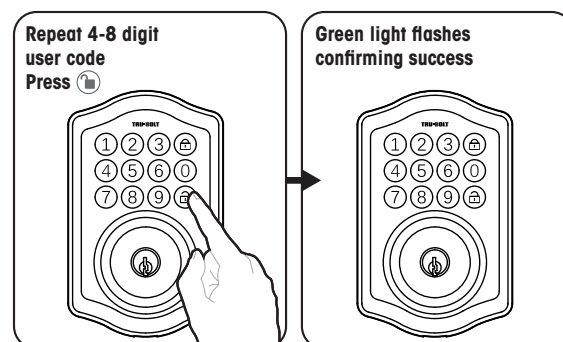
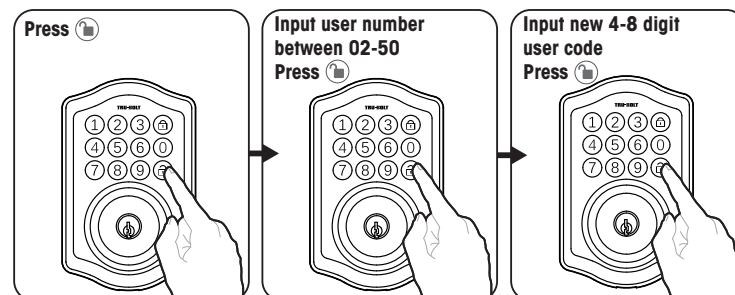
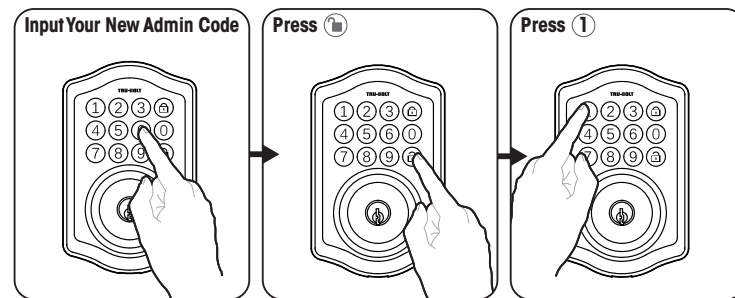

3 Unlocking Door with User Code

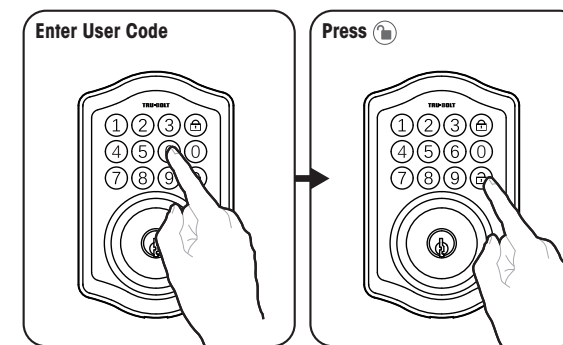

PROGRAMMING RECORD

My Codes:	Date Created
Programming Code _____ (6 digits) / /	
User Code 02 _____ (4-8 digits) / /	
User Code 03 _____ (4-8 digits) / /	
User Code 04 _____ (4-8 digits) / /	
User Code 05 _____ (4-8 digits) / /	
User Code 06 _____ (4-8 digits) / /	
User Code 07 _____ (4-8 digits) / /	
User Code 09 _____ (4-8 digits) / /	
User Code 10 _____ (4-8 digits) / /	
User Code 11 _____ (4-8 digits) / /	
User Code 12 _____ (4-8 digits) / /	
User Code 13 _____ (4-8 digits) / /	
User Code 14 _____ (4-8 digits) / /	
User Code 15 _____ (4-8 digits) / /	
User Code 16 _____ (4-8 digits) / /	
User Code 17 _____ (4-8 digits) / /	
User Code 18 _____ (4-8 digits) / /	

4 Deleting a User Code

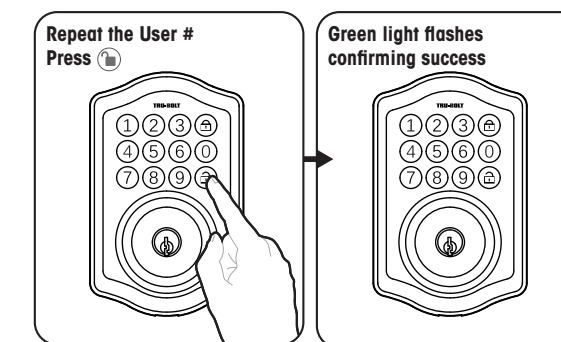
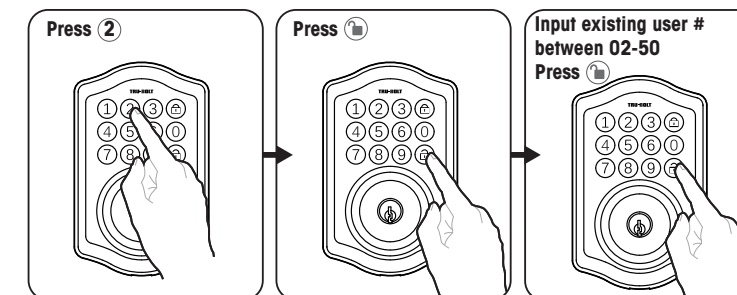
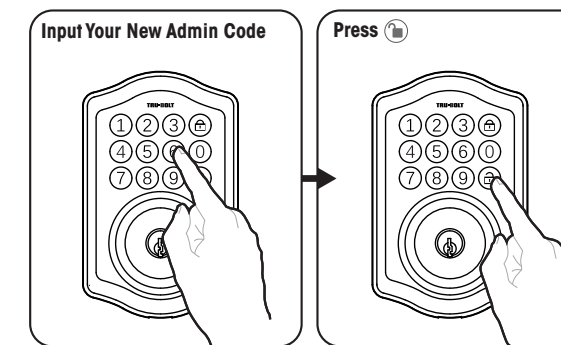

5 Deleting All User Codes

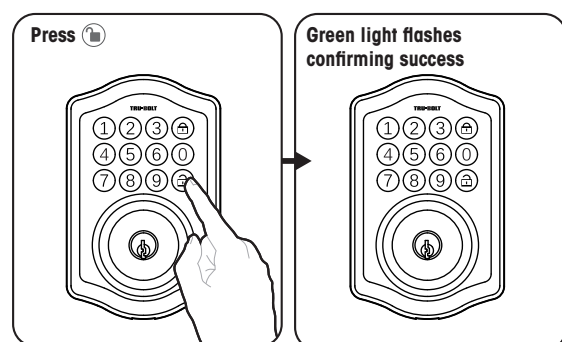
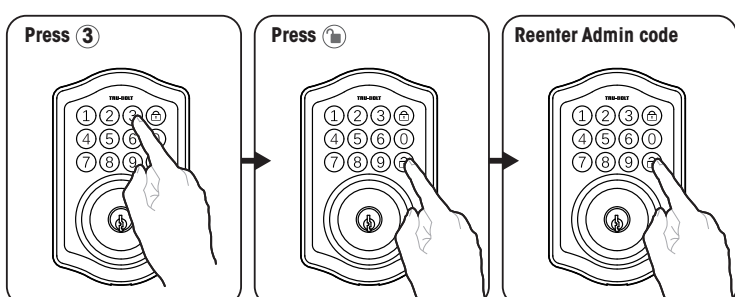
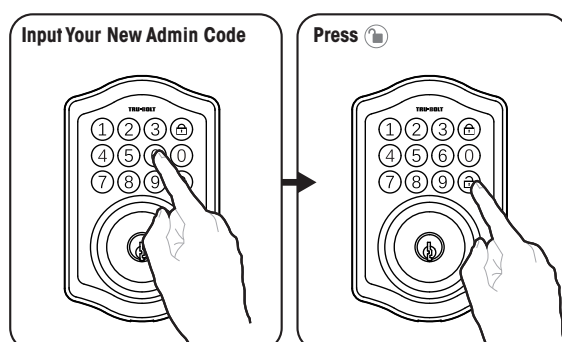

6 Additional Programming Functions

Programming Symbols

- Lock / Clear
- Administrator Code

Automatic Lock Function

SET OR CANCEL AUTO LOCK

You can set the lock to automatically close after each time the lock is opened. Time value range = 20 - 900 seconds, enter the following:

Set Auto Lock: → → 5 → → Time Value →

Hear 1 beep and Light Indicator illuminates green.

To cancel Auto Lock set the time to 00, enter the following:

Cancel Time Value Auto Lock: → → 5 → → 00 →

Hear 1 beep and Light Indicator illuminates green.

TEMPORARILY DISABLE:

While in Auto-Lock mode, unlock door using , within 10 seconds you must turn the locking knob by hand to the locked position, wait more than 2 seconds then turn the locking knob back to the unlock position. The Auto-Lock mode is now disabled.

RESTORE:

To restore the Auto-Lock function, turn the locking knob by hand to the locked position, wait more than 2 seconds or press the Lock button on the keypad.

Vacation Mode

With Vacation Mode enabled, the system enters into low-power consumption mode. During this mode, all buttons and functions will be disabled until they are re-enabled.

ENABLE:

→ → 10 → → 1 →

Once the door is locked then vacation mode will be engaged and all buttons and functions will be disabled

DISABLE:

To disable the Vacation Mode, you must press and hold for more than 3 seconds, then input followed by to unlock the door. Vacation Mode is now disabled.

NOTE: If you only press the for more than 3 seconds but do not input , the system will remain in Vacation Mode.

Secure Lock-out period

Warning sounds and LED flashes red after 4 incorrect code attempts: Keypad shuts down for 60 seconds.

7 Additional Programming Functions

SOUND ON AND OFF

You can "mute" or turn the "sound on" on your lock by entering the following. (Factory setting is sound on).

→ → 6 → → 1 or 2 →

1 = Sound Off

2 = Sound On

Sound Off (1) - Light Indicator illuminates green.

Sound On (2) - Hear 1 beep and Light Indicator illuminates green.

Restore Factory Settings

To reset the lock to the original factory settings including the Programming Code and all User Codes follow these steps:

1. Remove one battery for 10 seconds.
2. Reinsert the battery and wait for a long and short beep
3. Press 3 times within 3 seconds.
4. The lock will beep and the light indicator will turn green.

Low Battery Warning

Beeps and LED flashes red 7 times. Replace with good quality alkaline batteries.

Note: Removing batteries does not erase active Administrator or User Codes.

Consumer Friendly Message Guide

Unlock / Valid programming:	1 long beep and LED illuminates green
Lock:	2 short beeps and LED illuminates red
Invalid Programming:	2 short beeps and LED flashes red twice
Low Voltage:	Short beeps and LED flashes red seven times
Super Low Voltage:	4 short beeps and LED flashes red four times
4 Incorrect code entry attempts:	2 short beeps and LED illuminates red each attempt
Power on:	1 long beep and 1 short beep and LED illuminates green
Chip Reset:	1 long beep and 1 short beep and LED illuminates green (may occur several times or once in a while)
Lock Error:	3 long beeps LED flashes red three times
Repeat operation after Lock Error:	2 short beeps three times LED flashes red six times

Troubleshooting

Issue	Solution
Interior Knob will not turn	Knob or vertical tailpiece is installed in incorrect position. • Remove Interior Assembly and reposition the Interior Knob. With the Deadbolt Latch retracted verify that the tailpiece is vertical.
Lock will not function electronically	• Check that all batteries are fresh high quality Alkaline Batteries. • Check for proper polarity (+ -) of all batteries. • Check that the Control Wire is attached to the Interior Assembly and not damaged. • Check each wire for loose or disconnected wires. • Disconnect the wiring harness and reconnect the wiring harness.
Lock gives error signal when opening or locking and Deadbolt Latch will not extend or retract completely when door is closed	• Unlock door using Key or Interior Knob. While door is open, check that the Deadbolt Latch operates smoothly. • Check for proper alignment of the strike plate, adjust as needed to assure there is no binding against the Deadbolt Latch. • Make sure tail piece is in the vertical position and straight up and down.
Deadbolt Latch is sticking	Installation screws of the lock may be too tight and have to be loosened. • Remove Interior Assembly. • Slightly loosen the Mounting Plate screws. • Lock and unlock using the Key. • Reattach Control Wire and Interior Assembly.
Keypad not working	• Wait 60 seconds; keypad may be locked out due to incorrect code. • Replace with 4 high quality alkaline batteries.
Keypad beeps and LED flashes	• Replace with 4 high quality alkaline batteries.

Contact Us First! Do Not Return to Store

EMAIL: locks@lewishymaninc.com
WEBSITE: www.truboltlocks.info
ADDRESS: Consumer Assistance Dept.
Lewishyman, Inc.
860 East Sandhill Avenue
Carson, CA 90746 USA
TELEPHONE: US/Canada 800-860-1677 Ext. 1801 (Toll Free)

How to Operate Your New Lock

To Lock your lock - press the lock button.

To Unlock your lock - enter your user code (not the Admin Code) and press unlock.

Limited 1-Year Electronic Warranty

Limited Lifetime Mechanical and Finish Warranty

This Tru-Bolt® product comes with a 1-Year Limited Warranty on Electronic Parts and a Limited Lifetime Mechanical and Finish Warranty against defects in materials and workmanship under normal use to the original residential user. Proof of purchase and ownership is required for the warranty to be in effect. This warranty is non transferable and applies to the original purchaser only, as long as the original purchaser occupies the residential premises upon which the product[s] was originally installed. This warranty DOES NOT COVER removal and reinstallation of product[s], scratches, abrasions, deterioration due to the use of paints, solvents or other chemicals, abuse, misuse, or product[s] used in commercial applications, does not cover any losses, injuries to persons/property or costs, and shipping and freight expenses required to return product[s]. In no event shall Tru-Bolt® be liable for any special, incidental or consequential damages. If this product[s] is considered a consumer product, please be advised that some local and state laws do not allow limitations on incidental or consequential damages or how long an implied warranty lasts, so that the above limitations may not fully apply. Refer to your local laws for your specific rights under this warranty. If there are any problems please call our customer service with any questions or concerns.

DO NOT RETURN TO STORE!

If any parts are missing or damaged, please call Customer Service Toll free at 1-800-860-1677 (Toll Free, M-F 7am - 5pm PST).

Online installation videos can be viewed at TruBoltLocks.info.
Don't forget to register your lock at TruBoltLocks.info for updates.

Don't forget to register your lock at Truboltlocks.info for updates.